

# Dew point hygrometer TP3-S



Dew point hygrometer TP 3-S



TP 3-S with dew point sensor and semiconductor thermometer packed in mock-leather cover (option)

The TP 3-S is a humidity sensor working on the dew point mirror principle. The reflectivity of the mirror is checked by an optoelectronic system. The output signal controls the thermoelectric cooling of the mirror in such a way that the thickness of the dew or ice deposit remains constant. Built into the mirror is an electronic thermometer which measures the dew point directly.

The special features of the TP 3-S are:

- extremely low power consumption (battery operated)
- small mirror with fast response
- low weight

The TP 3-S is specially suitable for applications where low weight and low power consumption are important, such as in radiosondes, aircraft systems, etc.

## Description

1. The TP 3-S consists of the sensor with built-in ventilator, the connecting cable approx. 1 m in length and the control electronics built in plastic housing.

A mock-leather cover for the housing is also available as an optional extra.

2. Either a semiconductor or a thermocouple thermometer can be built into the mirror.

If a thermoelement is used, the small voltages are preamplified.

3. Thermometers for measuring of the air temperature are available optional.

## Technical Data

Sensitivity Semiconductor thermometer	10 mV/K. 0°C $\pm$ 0,513 V or (12175 $\Omega$ -R)/127.096
Thermocouple thermometer with preamplifier	approx. 24 mV/K calibration polynomial supplied
Operating voltage	10...15 VDC
Power consumption (approx.)	25 mA at 50% rel. humidity max. 180 mA at 5% rel. humidity
Accuracy Semiconductor thermometer	$\pm$ 0,25 K
Thermocouple thermometer	$\pm$ 0,15 K from -20°C to +50°C $\pm$ 0,25 K from -60°C to -20°C
Measuring range Semiconductor thermometer TH	-30°C...+50°C
Thermocouple thermometer TT	-80°C...+60°C
Speed of response Semiconductor thermometer TH	approx. 2 K/s + tD*
Thermocouple thermometer TT	approx. 5 K/s + tD*
Maximum possible cooling	approx 40 K of the mirror at ambient +20°C ( $\Delta$ approx. 5,3% rel. humidity)

\*tD = time for layer to form on mirror:

at 0°C and above:	less than 0.5 s
at -30°C:	approx. 20 s
at -60°C:	approx. 2 min

	Weight
Dew point sensor	165 g
Dew point hygrometer TP 3-S	600 g
Mock-leather cover	500 g

## Dimensions

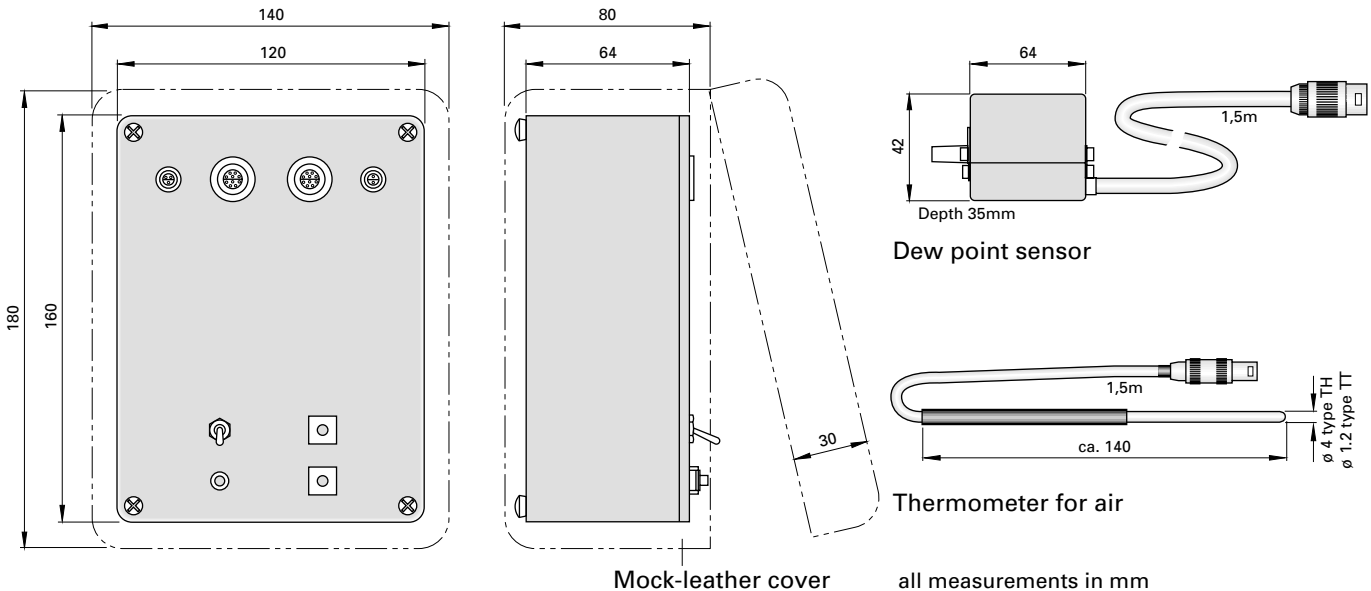

## Details for ordering

Dew point hygrometer and dew point sensor with semiconductor thermometer	TP3-SH
Dew point hygrometer and dew point sensor with thermocouple thermometer	TP3-ST

## Options

Thermometer TH for air temperature for	TP3-SH
Thermometer TT for air temperature for	TP3-ST
Mock-leather cover	

meteolabor reserves the right to make changes without further notice

Hofstrasse 92  
CH-8620 Wetzikon  
Internet: [www.meteolabor.ch](http://www.meteolabor.ch)

*meteolabor ag*

Phone +41 1 934 40 40  
Fax +41 1 934 40 99  
E-Mail: [sales@meteolabor.ch](mailto:sales@meteolabor.ch)